

# User' s Manual

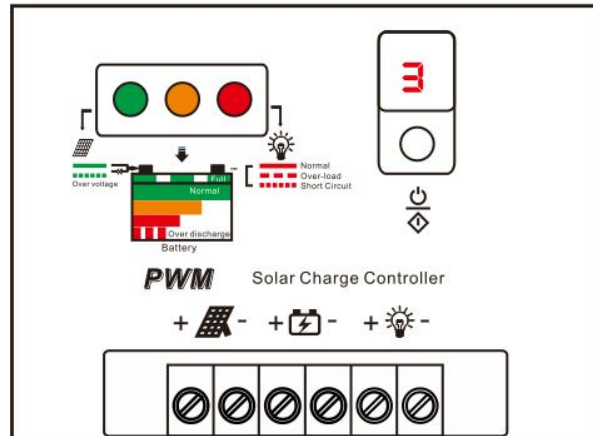

## **PWM** Solar Charge Controller

### 1. General Safety Instructions

Danger of explosion due to improper handling of batteries! Corrosive hazard by leaking battery acid! Keep children away from batteries and acid! Smoking, fire and naked lights are prohibited when handling batteries. Prevent sparking and wear eye protection gear during installation.

Solar modules generate power from light incidence. Even by low light incidence solar modules carry the full voltage. Therefore, work cautiously and avoid sparking during all work.

Use only well-isolated tools!

If the regulator is operated in a manner not specified by the manufacturer, the regulator' s constructive protective measures can deteriorate. The factory signs and marking may not be modified, removed or made unrecognizable. All work must be performed in conformity with the national electrical specifications and related local regulations!

When installing the regulator in foreign countries, information concerning regulations and protective measures must be obtained from the relevant institutions / authorities.

Do not begin the installation until you are sure that you have technically understood the manual and perform the work only in the order provided in this manual!

The manual must be available during all work performed on the system, third parties included.

This manual is a component of the system regulator and must be included with the regulator when given to a third person.

The Controller is equipped with a low power surge protection. The installer had to care for a efficient lightning protection.

## 2.Scope of Application

The charge regulator is only suitable for regulating photovoltaic solar modules. Never connect another charging source to the charge regulator. This can destroy the regulator and / or source.

The regulator is only suitable for the following chargeable 12V or 24V battery types:

- Lead storage batteries with liquid electrolytes
- Sealed lead storage batteries; AGM, GEL

Important!The regulator is not suited for nickel Cadmium, nickel metal hydride, lithium ions or other rechargeable or non-rechargeable batteries.

The regulator may only be used for the particular solar applications provided.Also,observe that the permitted, model-specific, nominal currents and voltages are not exceeded.

## 3.Installation

Install the regulator near the battery on a suitable surface. The battery cable should be as short as possible and have a suitable cable diameter size to minimize loss, e.g. 4 mm<sup>2</sup> at 20 A and 2m length.A temperature compensated final charge voltage will extend the batteries lifetime and uses the optimum charge capacity.

Do not install the controller to direct sunlight.

To ensure the air convection on each side keep a distance of 10 cm to the regulator.

Connecting the Regulator

- 1.Connect the battery to the charge regulator - plus and minus
- 2.Connect the photovoltaic module to the charge regulator - plus and minus
3. Connect the consumer to the charge regulator - plus and minus

The reverse order applies when deinstalling!

An improper sequence order can damage the controller!

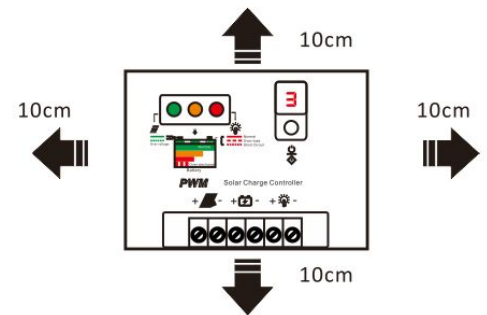

## 4. System indicator

### 1.Solar Indicator

- Off:without enough sun,charge off.
- Fast flashing:Buck/equalize charge
- Constant on:Acceptance charge
- Slow flashing:Float charge

### 2.Battery Indicator

- Green:Battery power is full( $V > 13.4V$ )
- Orange:Battery power is middle( $12.4V < V < 13.4V$ )
- Red:Battery power is low( $11.2V < V < 12.4V$ )
- Red-flashing:Battery over discharge.( $11.2V < V$ )

### 3.Consume Indicator

- Off:Controller output closed
- On:Output normal
- Slow Flashing: Continues over-current
- Fast Flashing:Short-circuit

### 4.System mode

### 5.Setting button

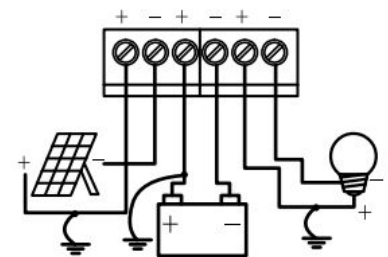

System connection

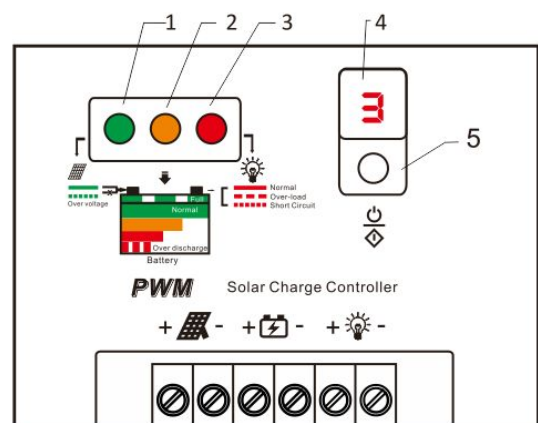

## 5. Setting the controller

Press the setting button to activate the mode display, press the button for 3 seconds, and select the desired mode.

0	Charge without load output	9	Light on+9 hour delay
1	Light on+1 hour delay	0.	Light on+10 hour delay
2	Light on+2hour delay	1.	Light on+11hour delay
3	Light on+3 hour delay	2.	Light on+12 hour delay
4	Light on+4 hour delay	3.	Light on+13 hour delay
5	Light on+5 hour delay	H	Open load manually
6	Light on+6 hour delay	C	Charge with load output
7	Light on+7 hour delay	L	Dusk to Dawn mode
8	Light on+8 hour delay	d	Debug mode

## 6. Mode description

mode	Mode description
<b>0</b>	pure charger mode: This mode will turn off the load output, but the logic of charging is still valid; if the load is directly connected to the battery, it can still receive power output. Note: connecting the load directly to the battery does not have over-discharge protection and overload, short circuit protection.
<b>1-3.</b>	light-control + delayed mode: consume automatic turn on after sun goes down, build-in timer start counting. When timer reaches setting mode, consume automatic turn off.
<b>H</b>	manual mode-Hand(H): Open or close the consume output manually. In this mode, every time you press the Settings button, you can open or close the consume.
<b>C</b>	universal controller mode-Current(C): Using this mode will cancel the optical control, time control function, the output delay and related functions to retain all other functions as a general universal controller (buttons control the load through output on or off).
<b>L</b>	When there is no sunlight, the light intensity dropped to start the point, after the start signal being confirmed by 10 seconds delay of controller; when there is sunlight, the light intensity rise to start point. The controller will delay for one minute to turn off the output signal to confirm closure of the output and at the same time the load stop working.
<b>d</b>	used for system debugging, the same as pure light control mode, only the delay of the judgment output light signal control (1min/10s) has been canceled in order to retain all other functions.

## 7. Protective functions of the controller

- Protection against reverse polarity of solar modules
- Protection against reverse polarity of connected battery
- Short-circuiting at the module input
- Short-circuiting at the load output
- Protection against over charging
- Reverse current protection at night
- Overvoltage and under voltage protection
- Over load protection at load output
- Deep discharging protection/low voltage disconnect

## 8.Charging Program

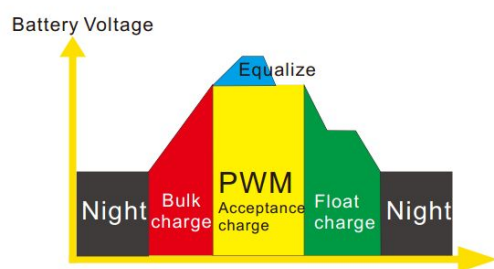

## 9.Mechanical drawing

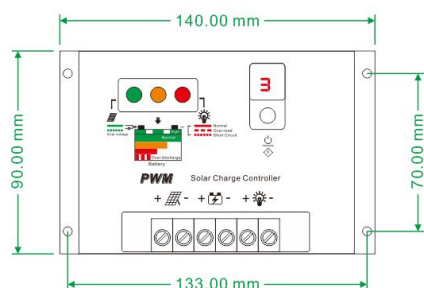

## 10.Technical parameter

Model	KT1230	KT1240
Rated charging current	30A	40A
Rated discharging current	30A	40A
Short-current protection	60A	60A
System voltage	12V/24V Auto adapt	
Over current protection	<1.3 maintain for 60s	
	<1.6 maintain for 5s	
	>1.6 shut down immediately	
Stand-by lost	<5mA	
Charge voltage drop	≤0.26V	
Discharge voltage drop	≤0.15V	
Max solar panel voltage	42V	
Operating temperature	-35°C to +55°C	
Equalize charging voltage	14.8V	
Bulk charging voltage	14.5V	
Acceptance charging voltage	14.2V	
Float charging	13.8V	
Charge return voltage	13.2V	
Discharge stop voltage	11.2V	
Discharge return voltage	12.6V	
Temperature compensation	N/C	
Control mode	PWM( Pulse Width Modulation )	
Maximum wire size	10AWG	
Size/weight	140×90×38mm/220g	